

The Quasi DC Recovery circuit (QR96) can be used to improve data recovery of receiver if the raw data is transmitted without any bit balancing. The QR96 measures the minimum and maximum levels of the AF output of the receiver, averages that and compares the original AF output signal with it. The module can be used in applications where raw (non-bit balanced) data need to be transmitted and received between two UARTs.

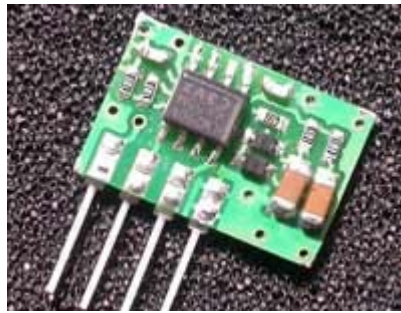

Figure 1: QR96

Features

- Recovery of data signals with frequencies down to 2Hz
- Tolerates time between bit transitions as long as 250ms
- Permits non-bit balanced data stream like straight ASCII
- Improves link margin by about 6dB, hence doubles the line of sight range on raw data
- Customisable to different data, preamble timing requirements (e.g. NMEA sentences)
- Wide supply range from 3.6V to 15V
- Small size: 18.5 x 10 x 5.5mm
- Pin outs and foot print compatible with Radiometrix SIL Receivers

Compared to conventional Data Slicer circuit currently used in the most of the FSK receivers, Quasi DC Recovery circuit can extract non-bit balanced data at RF signal level that is 6dB lower, resulting in double the range.

Conventional Data Slicers are based on simple 'RC integrate and compare' method to digitise the demodulated analogue signal, whereas, the QR96 samples positive and negative peaks of the Audio (AF) output and then averages them, before using that voltage as the comparator reference. QR96 behaves better on very unbalanced (raw) data, and at the start of bursts (where the simple RC takes time to acquire or charged to the mid average point).



User interface

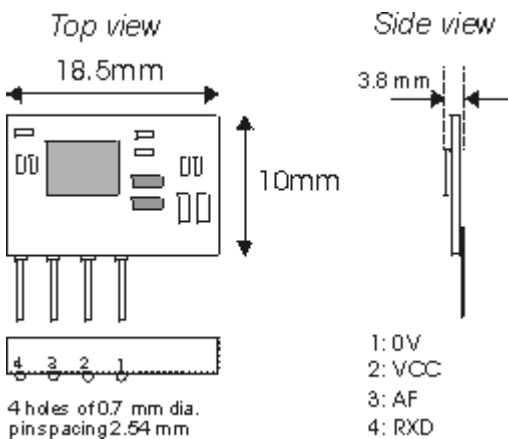

Figure 2: QR96 pin-out and dimension

QR48 pin	Name	Function
1	0V	DC supply ground
2	Vcc	3.6V - 15V
3	AF in	AF input is connected to the AF output of the receiver, requires signal level of 0.6V - 1.2V peak to peak on top of a DC bias level of 0.5-1.5V
4	RXD	Received Data output is open collector, an external 10kΩ pull-up resistor to the VCC is required. RXD will be inverted with respect to AF In

Note: 20ms of preamble (55hex or square wave signal) should be received from transmitter for the mark:space ratio of the RXD to stabilise to 50:50 on standard QR96. However, data packets with gaps >250ms (e.g. GPS NMEA data) would require extended preamble of up to 100ms.



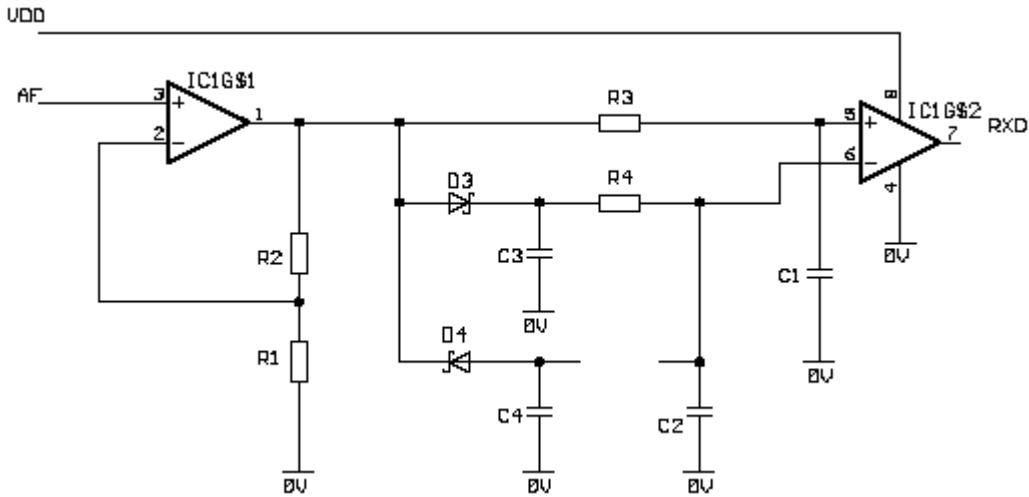

Figure 3: Schematics of QR96

Application Circuits

Expanded plan

Figure4: Typical wireless RS232 interface with RF modules and QR96

Limitation of liability

The information furnished by Radiometrix Ltd is believed to be accurate and reliable. Radiometrix Ltd reserves the right to make changes or improvements in the design, specification or manufacture of its subassembly products without notice. Radiometrix Ltd does not assume any liability arising from the application or use of any product or circuit described herein, nor for any infringements of patents or other rights of third parties which may result from the use of its products. This data sheet neither states nor implies warranty of any kind, including fitness for any particular application. These radio devices may be subject to radio interference and may not function as intended if interference is present. We do NOT recommend their use for life critical applications.

The Intrastat commodity code for all our modules is: 8542 6000.

R&TTE Directive

After 7 April 2001 the manufacturer can only place finished product on the market under the provisions of the R&TTE Directive. Equipment within the scope of the R&TTE Directive may demonstrate compliance to the essential requirements specified in Article 3 of the Directive, as appropriate to the particular equipment.

Further details are available on The Office of Communications (Ofcom) web site:

[Licensing policy manual](#)